

## Description

The cleverly designed housing ensures particularly quiet and trouble-free operation. The rotatable connection can be rotated by 360°, depending on the system integration.

Mounting options in horizontal or vertical position are available.

Possible features:

500 watts, 700 watts, 900 watts motor; Heating 300 watts Ozonator; Pneumatic switch; 230V / 50Hz, 230V / 60Hz and 110V / 60Hz, connection fitting inside  $\varnothing$  or outside  $\varnothing$  32 mm



## Features

- 220 V / 50 Hz
- 220 V / 60 Hz
- 110 V / 60 Hz
- vibration damper fixing kit
- Pneumatic switch  
Start pressure: 80mBar +/- 3 mBar  
Stop pressure: 110 mBar +/- 3 mbar
- Cable L = : 0,5 / 1,0 / 2,0 / 2,5 m
- Ozone lamp (2,6 Watt, 12 mA)
- Heater 300 watts (Inkl. Overload temperature 80°C +/- 5°C, Thermal fuse 117°C +/- 5°C)
- IP X5 (in horizontal position)
- Protection class II
- Conform to standards (EN 60 335-1 EN 60 335-2-41 )
- TÜV certified

## Sizes

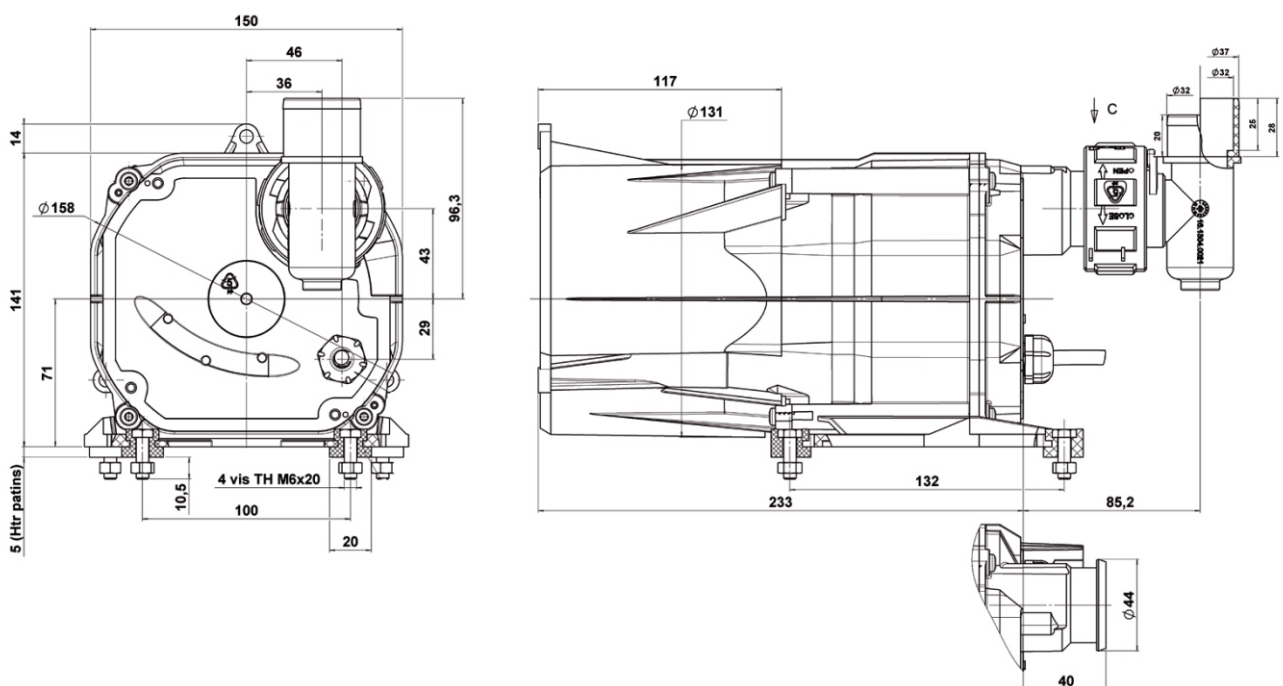

Performance curve

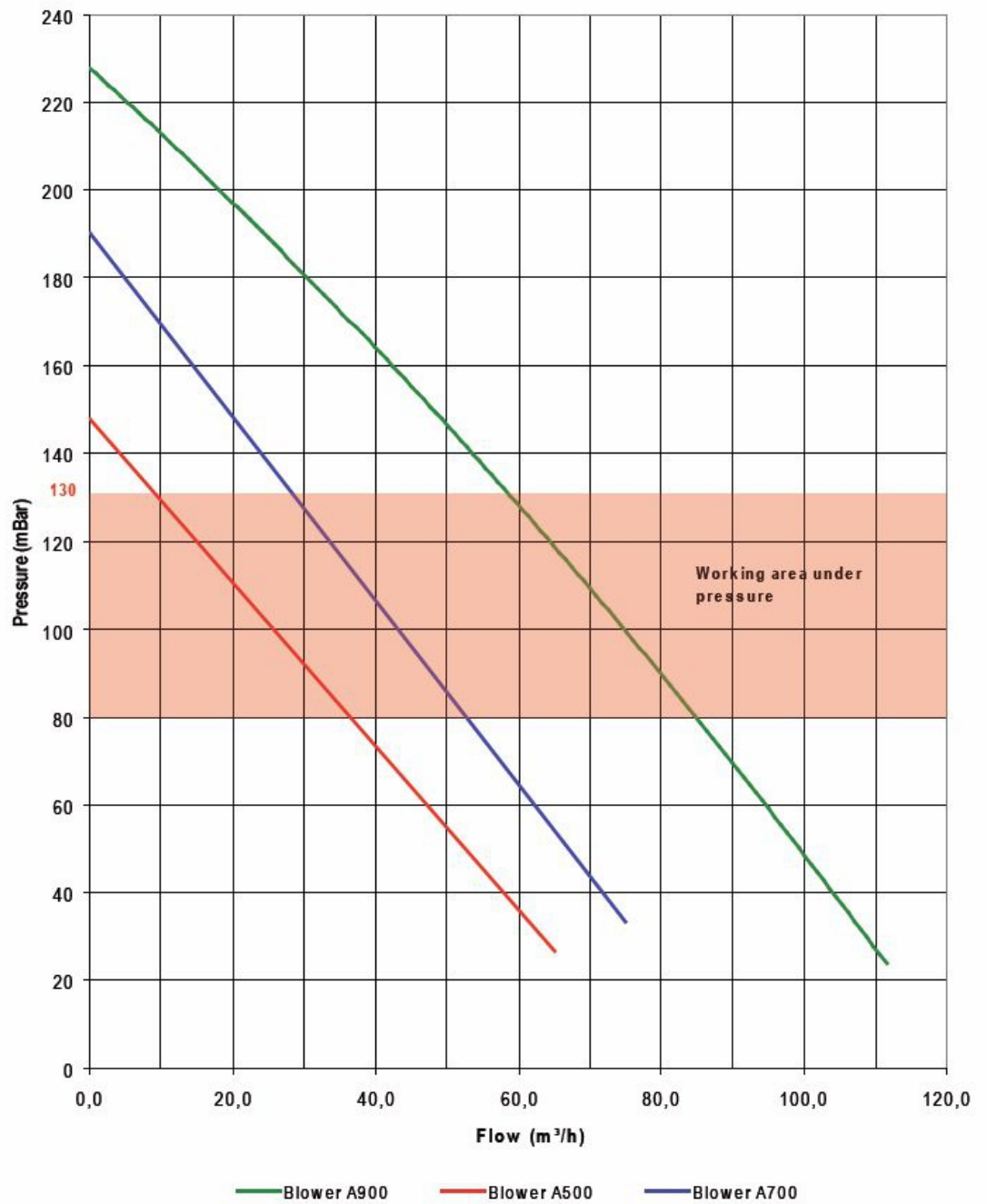

Accessoires

