

# Data sheet

Index: 11.05.2004



## Blower Type G-05HE1L / G-08HE1L / G-10HE1L



**Bypass-blower with motor 500W, 800W or 1000W with electronic, air-heater and thermistor 120°C**

### Motor

- **G-05HE1L:** Bypass-motor 500W: single-stage
- **G-08HE1L:** Bypass-Motor 800W: single-stage
- **G-10HE1L:** Bypass-Motor 1000W: double-stages
- Thermoprotection for motor

### Heater

- Heater 300W
- With thermostate 85°C und thermofuse 121°C

### Electronic

- Electronic with microprocessor
- Electrical fused maximum outlet-temperature
- Additional function: light
- Niveau-sensor for light connectable
- Touchpad with LED's for:
- Power On/Off; +, -, Light
- programs modulation; autom. switch off included

### Housing

- Material of housing: polycarbonat (PC)
- Compact design, shaped for under-bath-tub-use
- Protection IPX5

### Flow measurement 800 W

Pressure (bar)	Air amount(m <sup>3</sup> /h)
0,02	46
0,05	41
0,10	30
0,11	max. pressure

### Flow measurement 1000 W

Pressure (bar)	Air amount(m <sup>3</sup> /h)
0,02	50
0,05	45
0,10	42
0,14	35
0,17	max. pressure

A	B	C	D	E	Weight
224mm	232mm	190mm	70mm	130mm	3,0kg

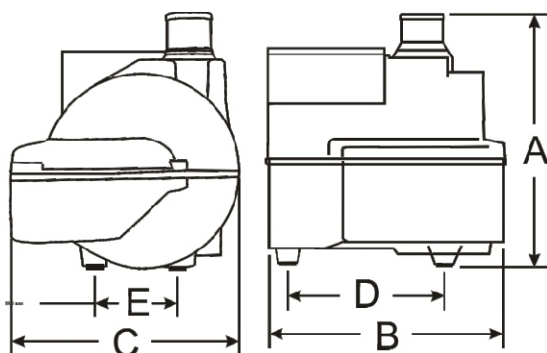

### Standard specification

Fixing: **Inside thread M5**

**Rubber legs**

Cable length: **2,0m**

**Blower G-05HE1L** ArtCode 610-010-05-55

**Blower G-08HE1L** ArtCode 610-010-08-55

**Blower G-10HE1L** ArtCode 610-010-10-55